

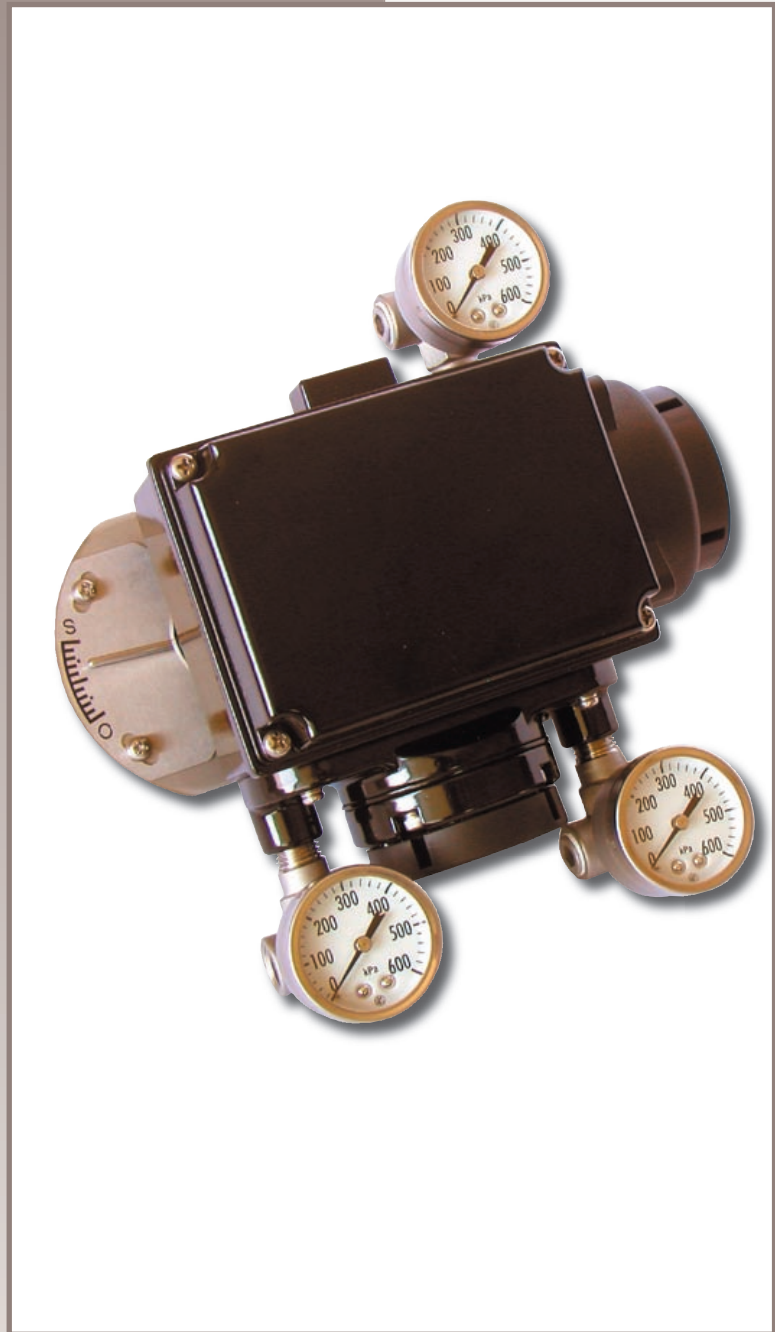

## Smart Valve Positioner



- **Easy to Use**
- **Flexibility in Installation**
- **High Reliability**
- **Single Model for Multiple Specifications**
- **HART™ Communication**



## Overview Smart Positioner SY Series

Smart positioner SY series are microprocessor-equipped, current pneumatic smart valve positioners for pneumatic actuators. The smart positioner receives a DC current signal from control devices and controls pneumatic valves. In addition to this basic function, the SY has communication capabilities, automatic configuration program, and self-diagnostics functions that will greatly increase productivity and the efficiency of plant operation. Calibration, configuration and self-diagnostics can be performed by using a HART™ communicator (or computer via HART™ modem.)

## Features

### Easy to Use – Auto Setup

The auto-setup function is a fully-automatic configuration program which specifies the actuator and adjusts the zero and span of the valve. The program can be turned on simply from a switch so that adjustments to the valve can be performed quickly and safely in hazardous areas.

### Valve Diagnostic

The following parameters can be monitored by HART™ communicator or control valve maintenance support system:

- Stick slip
- Cycle count
- Total stroke
- Shut-off count
- Travel histogram
- Max. travel speed

### Flexibility in Installation

The SY-1 positioner can be installed to the actuator by using a standardized mounting kit for long linear strokes.

### High Reliability

- Positive seating
 

The positive seating function completely shuts off the valve if the input signal becomes lower than previously set. This in turn enhances the full shut-off capabilities of the valves.
- Self-diagnostic
 

The self-diagnostic function provides the ability to check the status of the positioner at any time and to alert in case of failure.

## CCI's Smart Valve Positioner starts with intelligent design

### **Single Model for Multiple Specifications**

The SY settings can be changed without replacing any parts. A single model can be modified to suit any application.

- Flow characteristic: Linear, EQ%, quick opening or custom user characteristics (16 points)
- Actuator type: Double or single acting actuator

### **HART™ Communication**

HART™ communicator can be used for calibration, configuration and self-diagnostics.

### **Functional Specifications**

#### **Control Signal Input**

- 4-20 mA DC  
Input resistance Approx.  $600 \Omega$  / 20 mA DC  
(voltage between terminals 12V DC)

#### **Approvals**

- KEMA/ATEX Intrinsically safe approval  
II 1 G EEx ia IIC T4  
The barriers should be ATEX certified types and comply with the following conditions as follows:  
  
Input circuit (terminals I IN)  
 $U_i=29V$ ,  $I_i=95mA$  (resistively limited),  $P_i=690mW$ ,  $C_i=10nF$ ,  
 $L_i=220\mu H$   
  
From the safety point-of-view, the supply/input circuit shall be considered to be connected to earth.

#### **Output Characteristics**

- Linear, equal percentage, quick opening
- Custom user characteristics (16 points)

#### **Air Supply Pressure**

- 140 to 700 kPa (20 to 100 psi)

#### **Air Consumption**

- At stable output: 50%
- 10 l/min.(N) maximum at 400 kPa (60 psi)

#### **Maximum Delivered Air Flowrate**

- 250 l/min.(N) at 400 kPa (60 psi)

#### **Output Balanced Pressure**

- $55 \pm 5\%$

# CCI's innovative Smart Valve Positioner is engineered for efficient reliable performance in a simple package

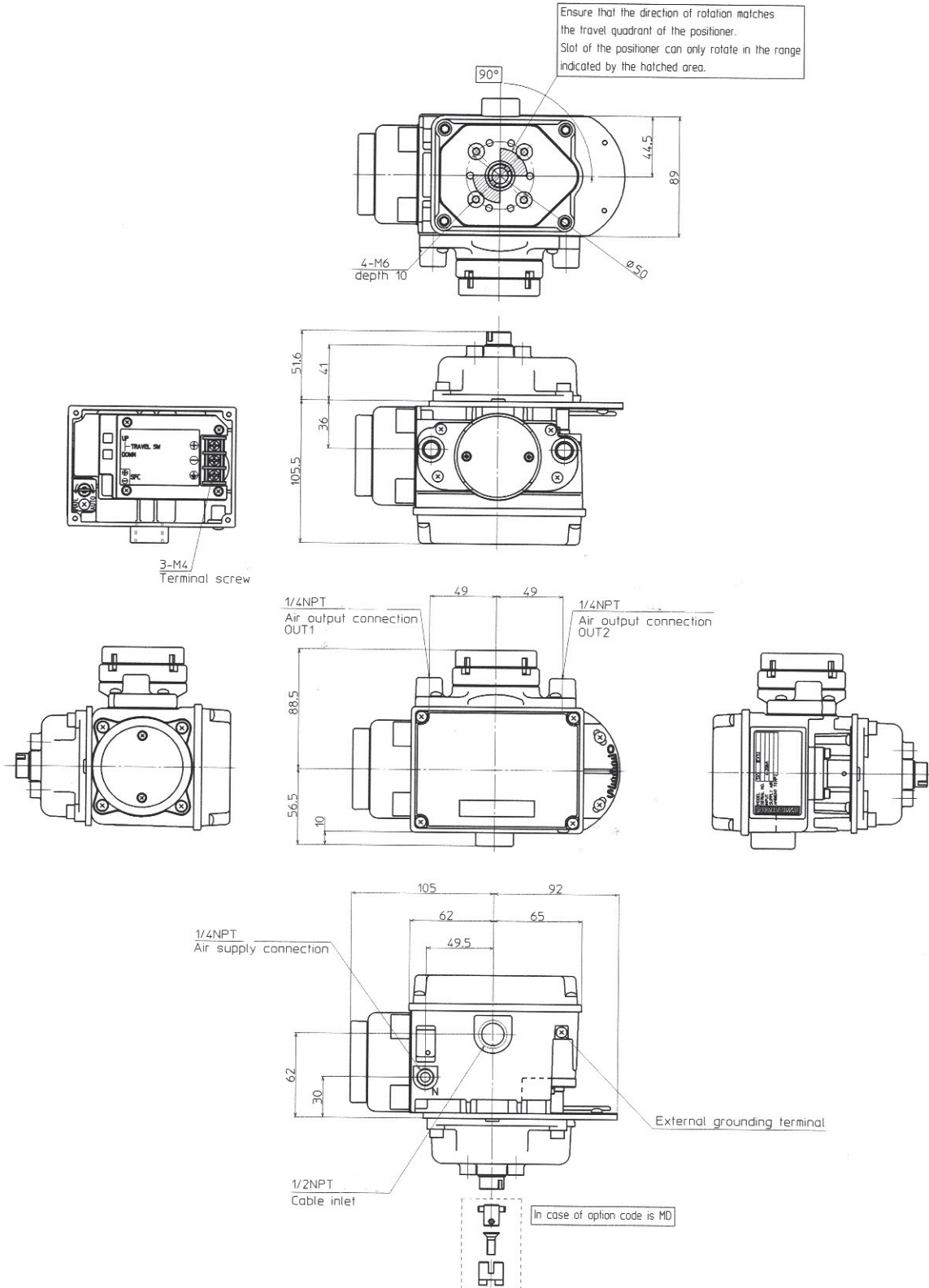

## Use this checklist to evaluate the benefits of CCI's Smart Valve Positioner

Benefits		Smart Valve	Competitors
1	One touch tuning for fast virtually effortless accuracy	<input checked="" type="checkbox"/>	<input type="checkbox"/>
2	High reliability for peace of mind and low cost of ownership	<input checked="" type="checkbox"/>	<input type="checkbox"/>
3	Flexibility in installation to adapt to your environment without additional costs	<input checked="" type="checkbox"/>	<input type="checkbox"/>
4	Self diagnostics for the ultimate in trouble free performance	<input checked="" type="checkbox"/>	<input type="checkbox"/>
5	Rugged construction for lasting reliability in the toughest conditions	<input checked="" type="checkbox"/>	<input type="checkbox"/>
6	HART™ Communication for superior accurate performance and compatibility	<input checked="" type="checkbox"/>	<input type="checkbox"/>
7	Built-in positive seating feature takes the guess work out of ownership	<input checked="" type="checkbox"/>	<input type="checkbox"/>
8	Single model/multiple applications means more options and less of a learning curve	<input checked="" type="checkbox"/>	<input type="checkbox"/>
9	Control valve maintenance diagnostics provides you with the insight you need for peak performance	<input checked="" type="checkbox"/>	<input type="checkbox"/>

**Lightning Protection**

- Peak value of voltage surge: 12 kV
- Peak value of current surge: 1000A

**Vibration Tolerance**

- 2 G (5 to 400 Hz)  
(with standard mounting kit STI/CCI)

**Ambient Temperature Limits**

- -40°C to 80°C for general model
- KEMA/ATEX Intrinsically safe: -40°C to 60°C

**Ambient Humidity Limits**

- 10% to 90% RH

**Configuration Tools**

HART™ communication or computer (CCI software) with HART™ modem.

**CE Conformity**

- Electromagnetic compatibility
- EN 61326: 1997 (CE marking)

**PERFORMANCE SPECIFICATIONS****Accuracy**

- $\pm 1.0\%$  F.S.  
( $\pm 2.5\%$  F.S. with custom output characteristics)

**Turning Range**

- 50° to 90°

**PHYSICAL SPECIFICATIONS****Enclosure rating**

- JISC 0920 watertight
- NEMA type 4X
- IP66

**Finish**

- Baked acrylic

**Color**

- Black

**Material**

- Cast aluminum

**Weight**

- Without pressure gauge : 1.9 kg
- With pressure gauge : 2.3 kg

## Easy to install and equally important – easy to use

### INSTALLATION

#### *Air Connections*

- 1/4NPT internal thread

#### *Electrical Connections*

- 1/2NPT

#### *Conditions of Supply Air*

- Particles: Maximum diameter 3 microns
- Oil mist: None acceptable
- Dew point: 10°C below ambient temperature

### TYPICAL INSTALLATION

Positioners SY series can be used by connecting the input signal cable (4-20 mA) the same as for the conventional type.

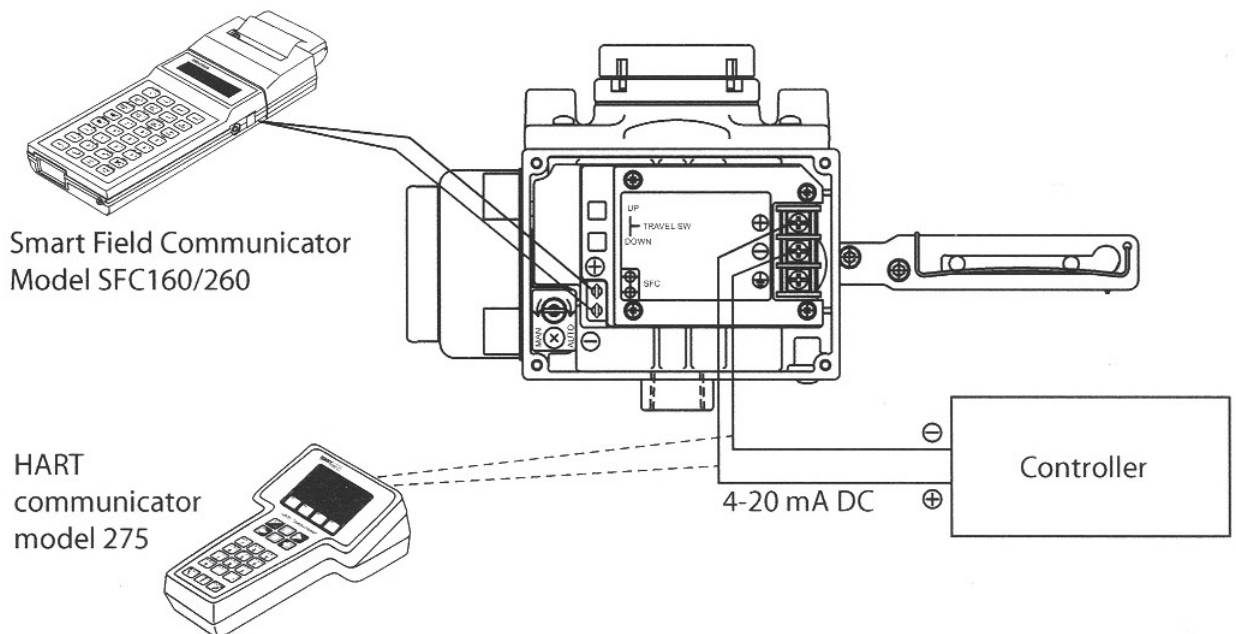

Figure 1: Wiring for SY series



**Oil & Gas**



**Nuclear**



**Fossil Power**



**CHP/Cogen**

Throughout the world, companies rely on CCI to solve their severe service control valve problems. CCI has provided custom solutions for these and other industry applications for more than 80 years.

**CCI locations worldwide.**

**CCI World Headquarters—**

**California**

Telephone: (949) 858-1877  
Fax: (949) 858-1878  
22591 Avenida Empresa  
Rancho Santa Margarita,  
California 92688  
USA

**CCI Austria**

**(Spectris Components GmbH)**

Telephone: 43 1 869 27 40  
Fax: 43 1 865 36 03  
Lemböckgasse 63/1  
AT-1233 Vienna  
Austria

**CCI China**

Telephone: 86 10 6501 0350  
Fax: 86 10 6501 0286  
Room 567/569  
Office Tower, Poly Plaza  
14 Dongzhimen South Avenue  
Beijing 100027  
China

**CCI FK**

**(Fluid Kinetics)**

Telephone: 805 644 5587  
Fax: 805 644 1080  
2368 Eastman Avenue, Suite 8  
Ventura  
California 93003  
USA

**CCI Italy**

**(STI)**

Telephone: 39 035 29282  
Fax: 39 035 2928247  
Via G. Pascoli 10 A-B  
24020 Gorle, Bergamo  
Italy

**CCI Japan**

Telephone: 81 726 41 7197  
Fax: 81 726 41 7198  
4-15-20 Shukunosho  
Ibaraki City, Osaka 567-0051  
Japan

**CCI Korea**

Telephone: 82 31 980 9800  
Fax: 82 31 985 0552  
26-17, Pungmu-Dong  
Kimpo City  
Kyunggi-Do 415-070  
Korea

**CCI Sweden**

**(BTG Valves)**

Telephone: 46 533 689 600  
Fax: 46 533 689 601  
Box 603  
SE-661 29 Säffle  
Sweden

**CCI Switzerland**

**(Sulzer Valves)**

Telephone: 41 52 264 95 00  
Fax: 41 52 264 95 01  
Im Link 11  
P.O. Box 65  
8404 Winterthur  
Switzerland

**Contact us at:**

**[info@ccivalve.com](mailto:info@ccivalve.com)**

**Visit us online for sales and service locations at:  
[www.ccivalve.com](http://www.ccivalve.com)**



**We Solve Control Valve Problems®**

DRAG is a registered trademark of CCI.  
©2005 CCI 801 ■ 06/05 5K