



QuickTrak™
Intelligent Digital
Valve Controller



CCI – 40 years and counting of innovative severe service actuator technology

- **Improved Performance**
- **High Reliability**
- **Precise Positioning**
- **Fast Stroking/Response**
- **Reduced Maintenance**
- **Quick Calibration and Tuning**



Before: Antiquated actuation schematic



After: Streamlined state-of-the-art QuickTrak™ solution

The QuickTrak™ System

CCI's QuickTrak™ system features a pneumatic digital valve controller that combines a microprocessor-based control system and a valve positioning device for dependable pneumatic actuator control for fast stroking and precise valve positioning applications.

Trends in Actuation Technology

Reliable pneumatic actuation systems have been available for severe service control valve applications for several years; however, using pneumatic actuator technology in valve applications such as turbine bypass, compressor recycle, and process steam posed new performance challenges. These include a need for:

1. Very fast stroking speed for relatively long stroke lengths.
2. Precise valve stem positioning requiring resolution similar to hydraulic actuators.

The limited flow capacity (Cv) of conventional valve positioners seriously reduces the speed of pneumatic actuators, so complex control schemes were developed using booster relays and quick exhaust valves to move the actuators faster. This solution met the fast stroking needs of the severe service market, but tuning all of the control accessories was tedious and time consuming, and the large number of components reduced overall system reliability. The complicated schematics also led to problems of overshoot and instability and worsened the resolution of the system.

CCI's Technological Breakthrough – The Future of Actuation Control

QuickTrak™ is specifically designed to answer the challenges faced by traditional actuators and meet the performance requirements of severe service applications, bringing tomorrow's technology to your process today.

QuickTrak™ Eliminates Mechanical Linkages — CCI's all-in-one total actuation system is free from cumbersome mechanical linkages to make your process more efficient and easier to control. This feature also makes it very simple to install and calibrate without any concern for backlash or linkage breakage. A magneto-restrictive probe, mounted inside the actuator to avoid damage, provides feedback to the controller to ensure highly accurate position.

QuickTrak™ Offers Remote Mounting Capabilities — Because QuickTrak™ functions without mechanical linkages, the controller, the direct drive pneumatic positioner module, and the fail-safe module can be easily mounted either on the actuator or remotely.

“The QuickTrak™ will do for actuation what DRAG® technology did for severe service valves.” *Stuart Carson, CCI President*

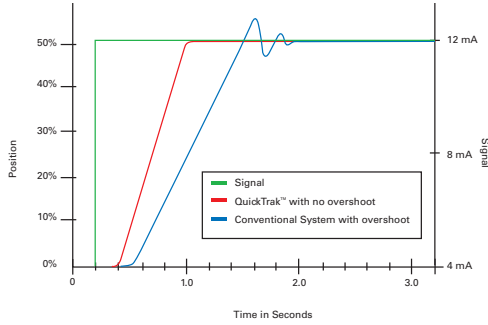

Figure 1: Stroke Speed/Dead Time on Seat QuickTrak™ provides fast stroking with small dead time on seat and no visible overshoot.

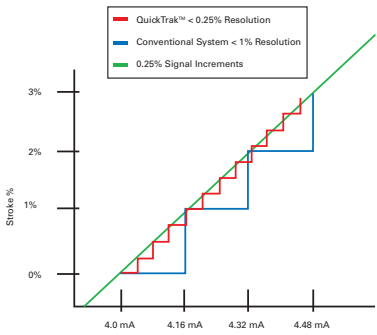

Figure 2: Resolution QuickTrak™ responds to 0.25% change in input signal, significantly improving process control.

QuickTrak™ Boasts High Capacity — The extremely high capacity of this system (roughly 50 times higher than conventional pneumatic positioners) makes it possible to achieve very fast position control without any booster relays. The high capacity spool also provides a stiffer actuator, allowing for control of small increment steps without overshoot.

QuickTrak™ Makes System Tuning a Breeze — Conventional pneumatic system calibration involves not only positioner calibration, but also tuning of all accessories individually. With QuickTrak™, the controller automatically calibrates and tunes the entire system with an easy user interface, maintaining its calibration between system outages.

QuickTrak™ Offers Easy Diagnostics — The state-of-the-art digital controller design enables easy communication with the plant’s control system and incorporates diagnostic capabilities. The control module is equipped with a PLC to store valve signature information and provide data for valve diagnostics. Communication to the QuickTrak™ is possible through a conventional 4-20 mA control signal as well as network protocols including HART™, Foundation Fieldbus, and Profibus (pending.)

QuickTrak™ Provides Unmatched Stroke Speed and Resolution — QuickTrak™ provides a digital pneumatic actuator control system capable of fast stroking speed (less than one second for a valve stroke of 20 inches/500 mm) and very accurate process control through precise stem positioning. Resolution for the system is less than 0.25%, which is comparable to hydraulic actuators and significantly better than the 1% available for actuators with positioners.

QuickTrak™ Will Meet Your Performance Needs —

QuickTrak™’s fast stroke and superior resolution and hysteresis allow the unit to be applied on severe service pneumatic actuators that demand fast stroking and precise positioning. CCI’s QuickTrak™ system covers a wide range of actuator size and stroke length requirements.

Table 1: Performance Comparison of Various Actuators

Valve performance characteristics		Pneumatic piston with positioner and accessories	Pneumatic piston with QuickTrak™ *	Hydraulic
Dead time on seat		>500 millisecond	<150 millisecond	<100 millisecond
Hysteresis	High Friction	<2.0%	<1.0%	<0.4%
	Low Friction	<1.0%	<0.5%	<0.4%
Resolution & deadband	High Friction	<2.0%	<1.0%	<0.1%
	Low Friction	<1.0%	<0.25%	<0.1%

* Resolution and hysteresis characteristics may be limited by valve/actuator combination. Consult factory for details.

CCI's innovative QuickTrak™ intelligent digital valve controller

QuickTrak™ Intelligent Digital Valve Controller

Position feedback probe

Remote mounting capability

Direct drive pneumatic positioning module

Requires no mechanical linkage for position feedback

Feedback Probe

Magnet

Extended Position **Retracted Position**

Push-button or hand-held communications

Remote mounting capability

Automatic system calibration and tuning

Advanced control module

	Conventional Pneumatics	Hydraulic	Electro-Hydraulic	QuickTrak® Pneumatic*
Improved Performance		X	X	X
High Reliability	X			X
Precise Positioning		X	X	X
Fast Stroking	X	X		X
Fast Response		X		X
Reduced Maintenance	X			X
Quick Calibration and Tuning		X	X	X
Low Air Consumption		NA	NA	X
Remote Mounting Capability				X

* Only CCI's QuickTrak™ provides hydraulic-like performance in a maintenance free, easy-to-tune actuation solution.

Use this checklist to evaluate the benefits of CCI's QuickTrak™ design

	Benefits	QuickTrak™	Competitors
1	Improves Plant Performance: Reduced dead time on seat, fast stroking with no visible overshoot, low percentage resolution and hysteresis.	<input checked="" type="checkbox"/>	<input type="checkbox"/>
2	Provides Cost-Effective Solution: High-performance pneumatic valve controller with electro-hydraulic performance.	<input checked="" type="checkbox"/>	<input type="checkbox"/>
3	Reduces System Maintenance: Fewer components increase reliability and reduce costly time spent tuning accessories.	<input checked="" type="checkbox"/>	<input type="checkbox"/>
4	Easy System Tuning: QuickTrak™ controller tunes the whole pneumatic system with easy user interface.	<input checked="" type="checkbox"/>	<input type="checkbox"/>
5	Eliminates Accessories Typically Found in High Performance Pneumatics: Quick exhausts, volume boosters, and lock-up valves are eliminated by high Cv digital positioning system.	<input checked="" type="checkbox"/>	<input type="checkbox"/>
6	Incorporates Integral Electronic Position Feedback: Mechanical linkages are eliminated by probe mounted inside actuator.	<input checked="" type="checkbox"/>	<input type="checkbox"/>
7	Designed Specifically for Severe Service Applications: Optional remote mounting capability allows resistance to temperature and vibration.	<input checked="" type="checkbox"/>	<input type="checkbox"/>
8	Redundant Actuation Control: Provides a simple, highly reliable, redundant actuation control system for critical service nuclear applications.	<input checked="" type="checkbox"/>	<input type="checkbox"/>
9	Integral Programmable Controlled Deceleration and Damping: Controlled valve stroke speed allows for full system protection and control.	<input checked="" type="checkbox"/>	<input type="checkbox"/>
10	Reduces Step Response Time: QuickTrak™ instantaneously responds to a change in input signals as low as 0.25%.	<input checked="" type="checkbox"/>	<input type="checkbox"/>

Travel Control

- Define signal polarity
- Define upper and lower limits
- Optional snap action relay protects valve trim

Tuning

- Set PID tuning parameters allow for full system tuning
- Full valve speed control
- Innovative damping function stiffens actuator for hydraulic-like performance

Inputs

- Calibrate input signal to maximize control span

Input Characterization

- User input signal characterization allows for optimal system performance

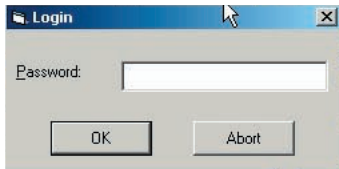
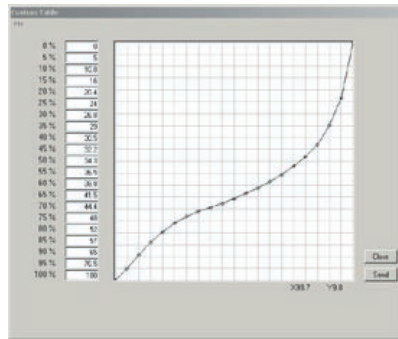
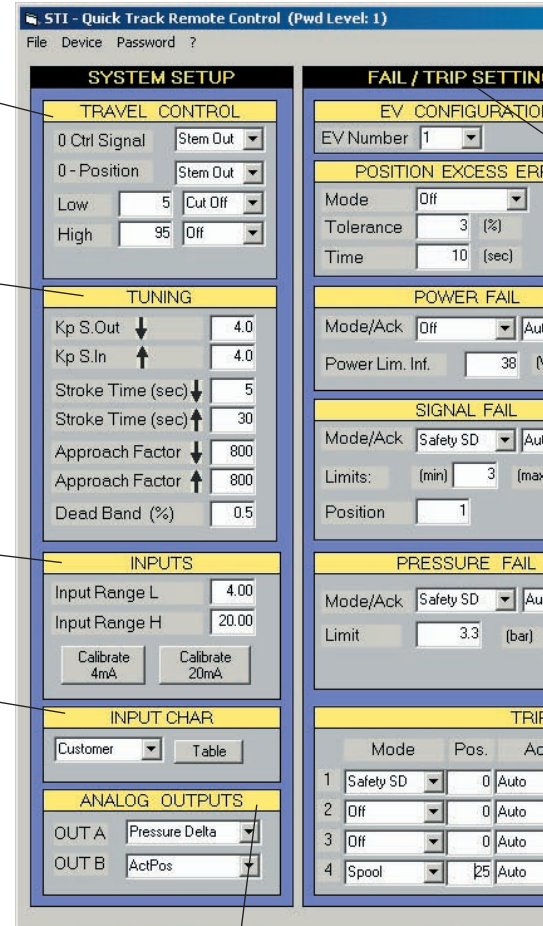

Password Protected

Secure your system with password protection

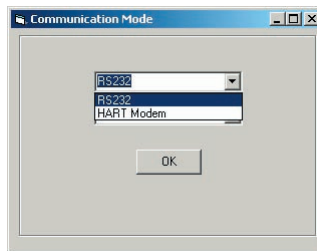

Select Communication Mode

QuickTrak's™ Remote Control software interacts with RS232 and HART™ communication protocol

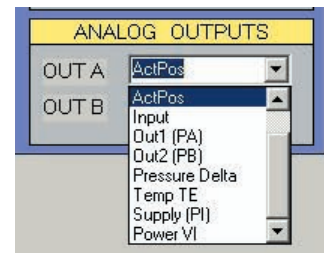

Analog Outputs

Select from a list of optional outputs

*CCI's QuickTrak™ allows for full control of all system tuning and calibration from the front panel. The remote control software is an optional user interface environment.

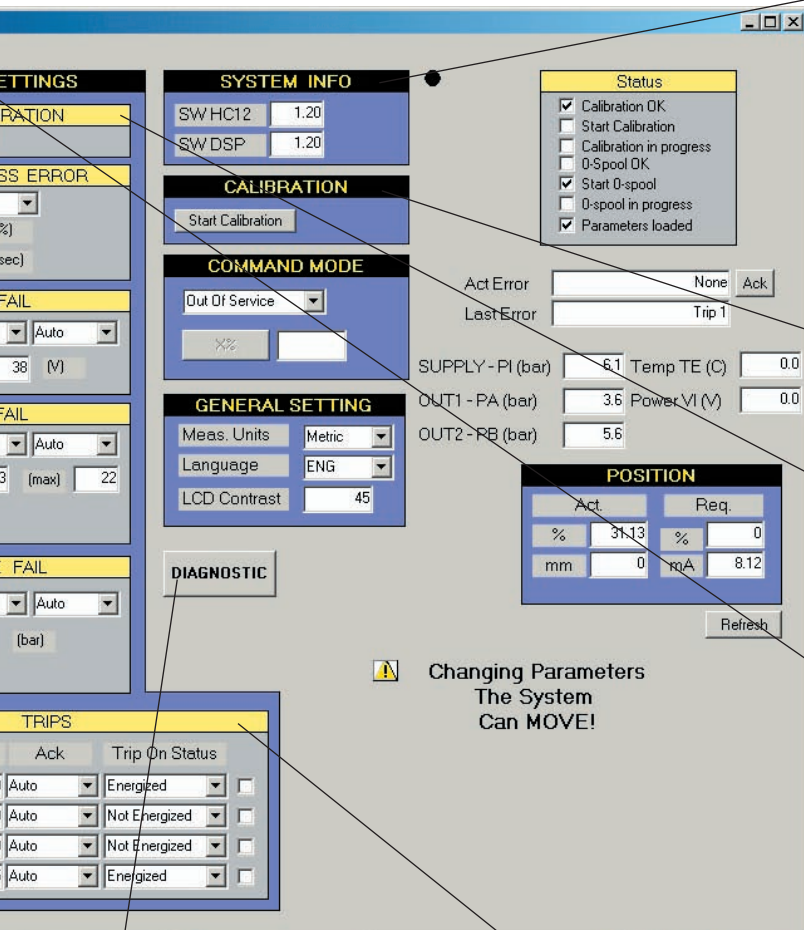

System Information

- In/Out service modes protect users and equipment
- Select measurement units and language for front panel and diagnostics readouts
- Easily witness
 - Valve position
 - System status
 - Error reports
 - System I/O's

Calibration

- One-touch system tuning and calibration

EV Configuration

- QuickTrak™ provides two integrated control relay outputs for control of safety systems and alarms

Failure/Trip Settings

- CCI QuickTrak™ provides a variety of settings and actions for failure and trip conditions. The system is fully customizable to meet the requirements of severe service applications

Failure Settings

- Four failure modes can be programmed independently or linked together
- Define your system requirements
 - Failure Mode - Safety trip or control point position
 - Acknowledgement - Automatic or hold
 - Limits - Easily set your safety limits

Trip Settings

- QuickTrak™ controller accepts four separate trip signals, with independent actions and priority

QuickTrak™ Diagnostic

Front panel digital communication of system status includes:

- Inlet, top and bottom pressure
- Demand Signal (%)
- Valve Position (%)
- Servo Temperature
- Error Codes (QuickTrak™ displays error code with alarm indicator)

On-line Valve Diagnostics – Optional Package (Pending)

- Alarm / Safety counter
- Trip counter
- System counter
- Position data log
- Delta P data log
- Temperature data log

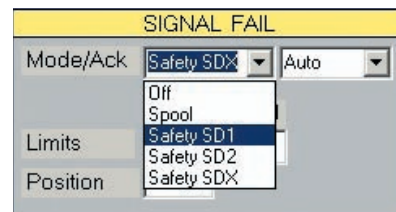

Designed with flexibility to meet your plant requirements.

QuickTrak™ Inputs

- **Input control signal:** Analog 4-20 mA, Hart™ 4-20 mA, or Fieldbus (pending)
- Over current protection:** Input circuitry limits current to prevent damage to controller
- Reverse polarity protection:** No damage occurs if loop current reverses
- **Power supply:** 120 Vac $\pm 10\%$ 50-60 Hz $\pm 5\%$; 240 Vac $\pm 10\%$ 50-60 Hz $\pm 5\%$; 120 Vdc $\pm 10\%$ 0.7A; 48 Vdc $\pm 10\%$ 1.5A; 24 Vdc $\pm 10\%$ 3A
- **Solenoid trip signal (if applicable):** 240 Vac, 110 Vac, 110 Vdc, 24 Vdc
- **Air supply:** Recommended operating range is 60 psig to 100 psig (4.5 barg to 7.0 barg). Air shall be free of oil, water, and dust; maximum particle size to be 5 microns. Comply with ISA 7.3, PARA.4.1

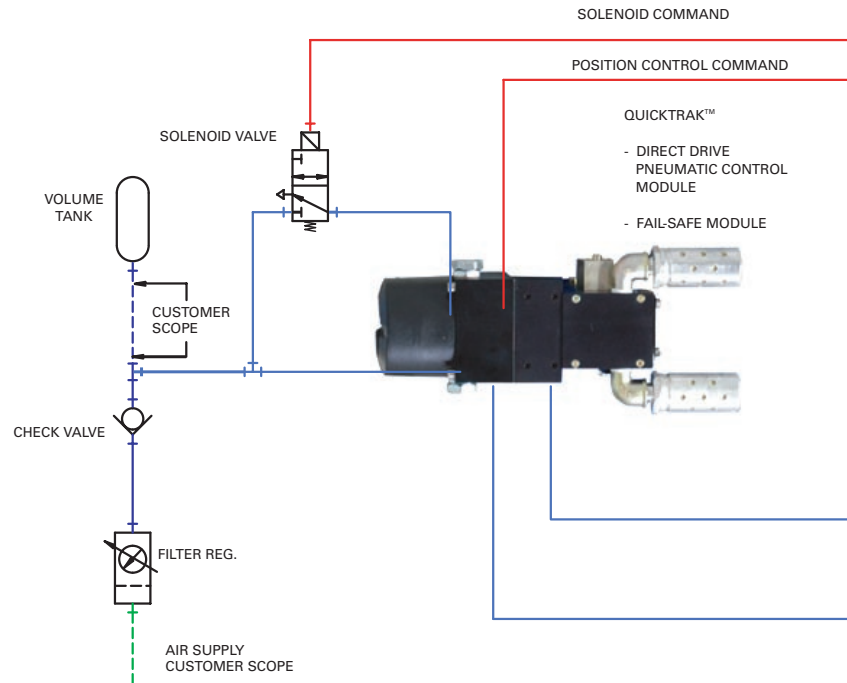

Exhibit: Control schematic for piston actuation with QuickTrak™

QuickTrak™ Outputs

- Analog 4-20 mA position feedback signal; two output signals available
- Hart™ communication feedback signal optional
- Digital communication for diagnostic package

Controller Type

Microprocessor-based closed-loop controller receives electric power for electronics and positioning module control.

Actuator Fail Mode Upon Power Supply Failure

Can be set to user-selected fail position: open, closed, or in-place. The system does not rely on any additional power source like batteries, making it extremely reliable and maintenance free.

Actuator Fail Mode Upon Input Signal Failure

Controller shutoff input signal: If the input falls below 3 mA or rises above 21 mA, the controller will set the actuator to user-selected fail position: open, closed, or in-place. Fail mode location can be selected at any discrete location between 0% and 100% of the stroke. Once the input signal is re-established within control signal limits, the controller will regain control within a few seconds and position the control valve according to the input signal.

Actuator Fail Mode Upon Air Failure

Can be set to user-selected fail position: open, closed, or in-place

Steady State Air Consumption

At (7 barg) 1.6 Nm³/hr

All agency approvals available Hart-Fieldbus-latest communication technology

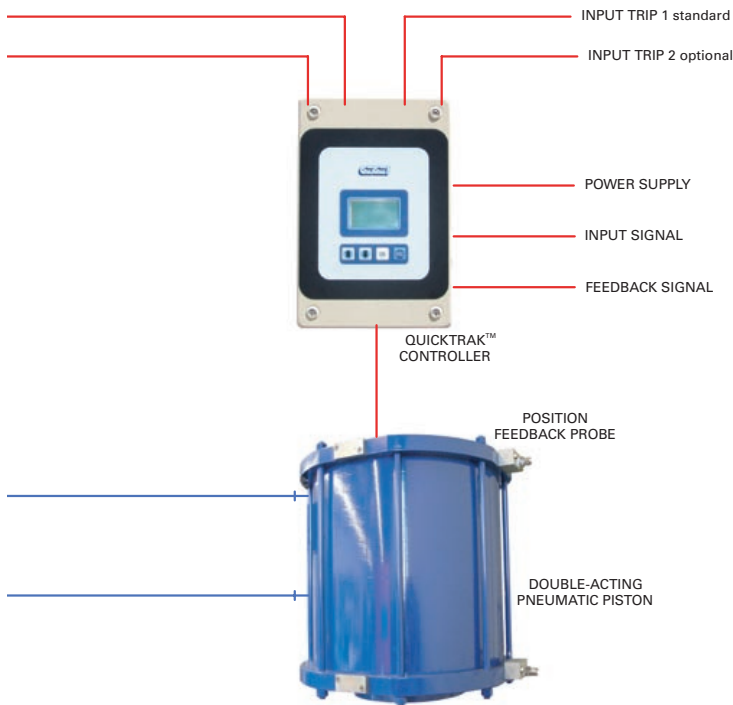

Valve System Performance

(control valve with low-volume double-acting piston actuator)

- Valve linearity: ISA-S75.13 < 0.1% terminal based
- Valve linearity: ISA-S75.13 < 0.2% zero based
- Valve hysteresis: ISA-S75.13 < 0.4%
- Valve dead band: ISA-S75.13 and IEC 60534-4 < 0.35%
- Valve resolution: ISA-S75.13 < 0.25%
- Valve dead time on seat: < 150 millisecond
- Valve stroke speed: < 1 second (*Consult factory for details*)

Communication Ports

- Hart™ protocol connection
- RS232 DB-9 connection for configuration
- Fieldbus protocol (pending)

Communication Protocols

- Hart™
- Fieldbus – optional (pending)
- Profibus PA – optional (pending)

Configuration Interface Options

- Local push-button communication – standard
- Laptop or PDA – optional

Valve Diagnostics

PLC provides option to store original valve signature and initiate alerts and alarms. Valve performance can be periodically compared to original valve signature to predict valve performance degradation and recommend preventive maintenance plan option. (*Consult factory for details*)

Electrical Classifications

- UL /CSA Ordinary Location IP66 NEMA 4X
- UL Hazardous Locations Explosion Proof Class 1 Division 1, Group B, C, D, enclosure rated NEMA 4X
- CSA Hazardous Locations Explosion Proof Class 1 Division 1, Group B, C, D, enclosure rated NEMA 4X
- ATEX II 2 G EExd IIC T6/T5 for motor enclosure and II 2 G EExd IIB T6/T5 for controller enclosure, EN 50014:1999, EN 50018:2000

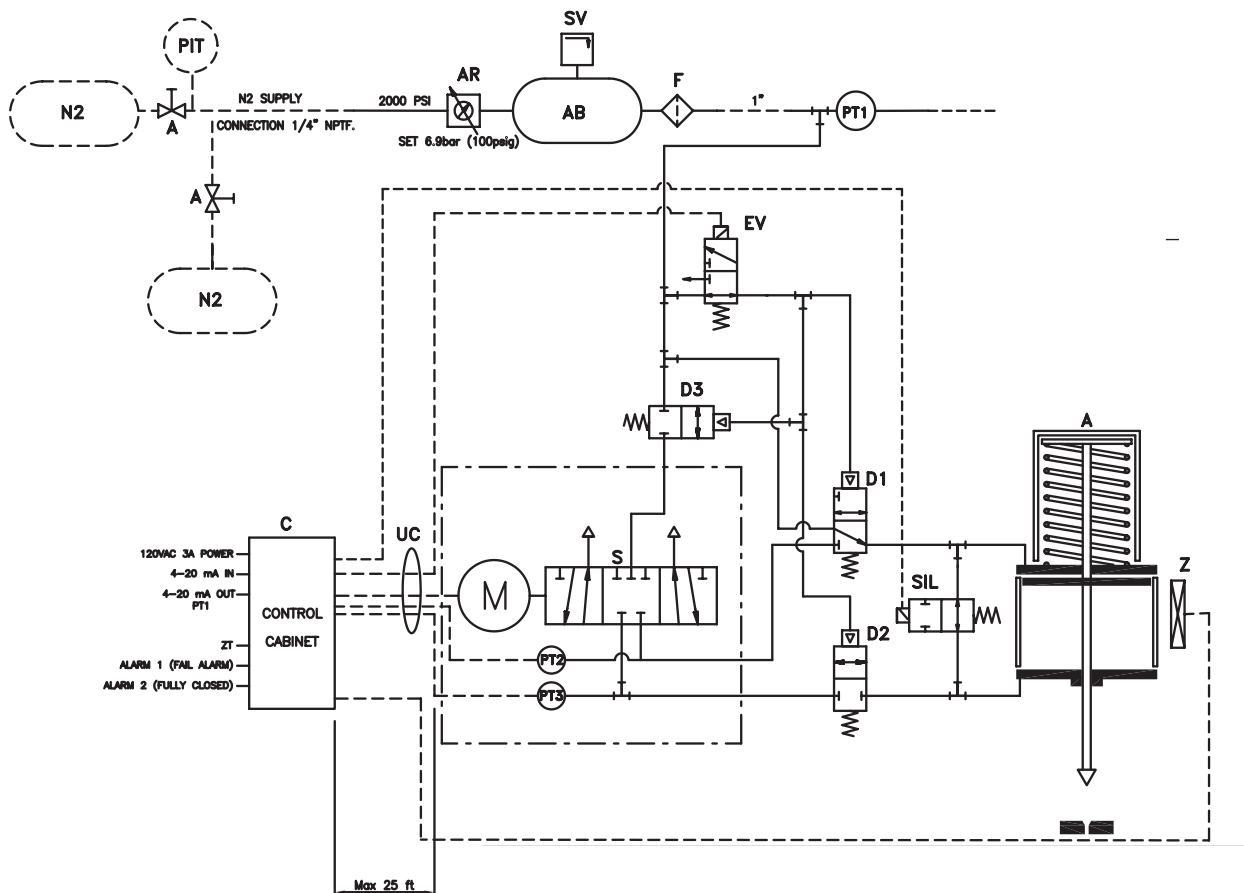

Fully Customizable, Zero Bleed, Remote Location Schematic

- Motive power nitrogen bottle (1 bottle per year)
- Stroke speed (adjustable in both directions)
 - Closing 4 to 5 minutes
 - Opening 1.5 seconds
- Fail safe
 - Spring fail open in 30 seconds

- Lock up system
 - Servo valve isolated
 - Full pressure on top of cylinder
 - Bottom cylinder isolated
- Remote Mounting 25'
- Independent trip signals

Configure the QuickTrak™ system to any unique DCS requirement

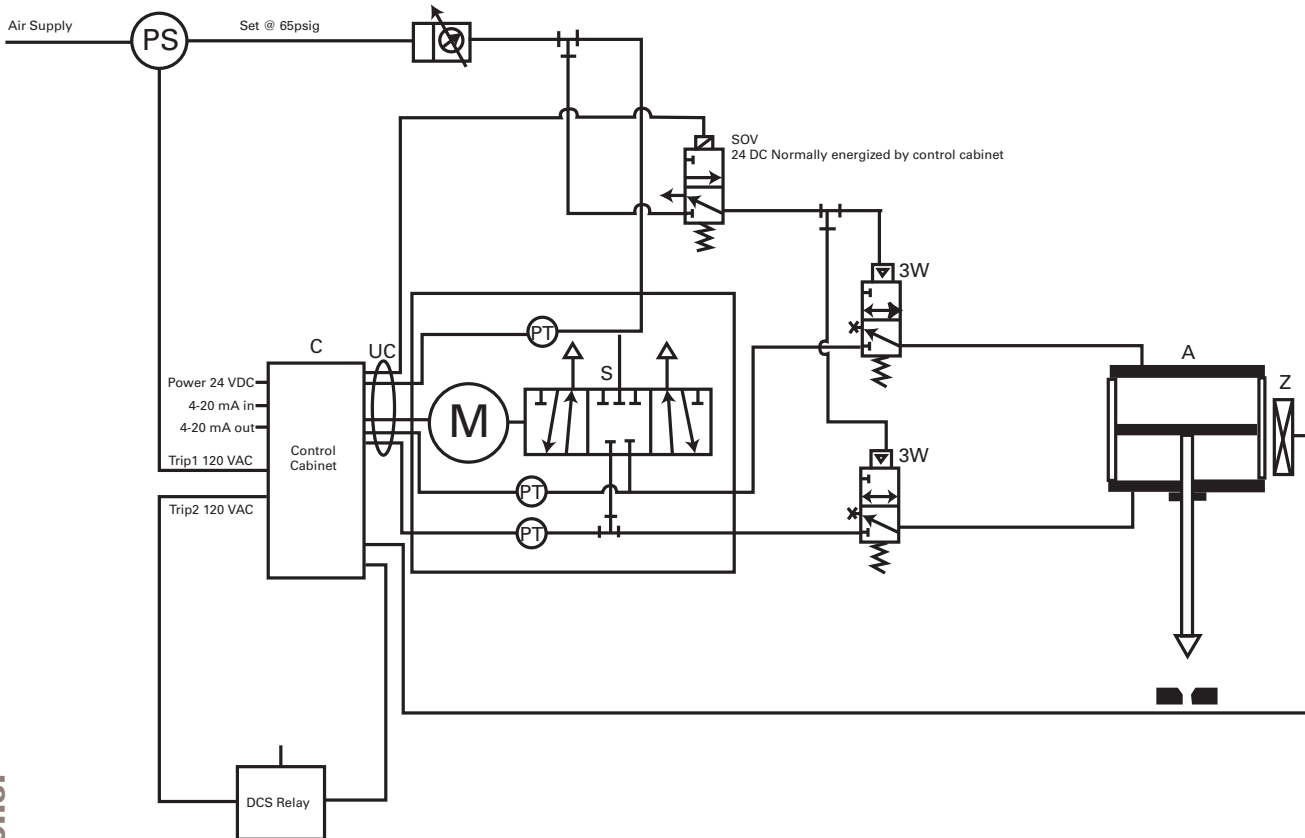

Custom Engineered Solution with Safety Lockup

- Opening/closing 4-10 seconds
- Fail in place schematic
- Panel remote mounted controller and servo
- Trip 1 controller by QuickTrak™
- Trip 2 independent from control room
- Control room interlock controlled by QuickTrak's™ energized relay
- Remote mounted design protects system from heat and vibration
- Custom stroking time protects equipment



Throughout the world, companies rely on CCI to solve their severe service control valve problems. CCI has provided custom solutions for these and other industry applications for more than 80 years.

CCI locations worldwide.

**CCI World Headquarters—
California**

Telephone: (949) 858-1877
Fax: (949) 858-1878
22591 Avenida Empresa
Rancho Santa Margarita,
California 92688
USA

**CCI Austria
(Spectris Components GmbH)**

Telephone: 43 1 869 27 40
Fax: 43 1 865 36 03
Lembockgasse 63/1
AT-1233 Vienna
Austria

CCI China

Telephone: 86 10 6501 0350
Fax: 86 10 6501 0286
Room 567/569
Office Tower, Poly Plaza
14 Dongzhimen South Avenue
Beijing 100027
China

**CCI FK
(Fluid Kinetics)**

Telephone: 805 644 5587
Fax: 805 644 1080
2368 Eastman Avenue, Suite 8
Ventura
California 93003
USA

**CCI Italy
(STI)**

Telephone: 39 035 29282
Fax: 39 035 2928247
Via G. Pascoli 10 A-B
24020 Gorle, Bergamo
Italy

CCI Japan

Telephone: 81 726 41 7197
Fax: 81 726 41 7198
4-15-20 Shukunoshō
Ibaraki City, Osaka 567-0051
Japan

CCI Korea

Telephone: 82 31 980 9800
Fax: 82 31 985 0552
26-17, Pungmu-Dong
Kimpo City
Kyunggi-Do 415-070
Korea

**CCI Sweden
(BTG Valves)**

Telephone: 46 533 689 600
Fax: 46 533 689 601
Box 603
SE-661 29 Säffle
Sweden

**CCI Switzerland
(Sulzer Valves)**

Telephone: 41 52 264 95 00
Fax: 41 52 264 95 01
Im Link 11
P.O. Box 65
8404 Winterthur
Switzerland

Contact us at:

info@ccivalve.com

**Visit us online for sales and service locations at:
www.ccivalve.com**



We Solve Control Valve Problems®

DRAG is a registered trademark of CCI.
©2005 CCI 565 ■ 06/05 5K